

1 Watt DO-41 Hermetically Sealed Glass Zener Voltage Regulators

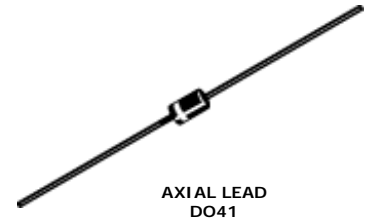

AXIAL LEAD
DO41

Absolute Maximum Ratings $T_A = 25^\circ\text{C}$ unless otherwise noted

Parameter	Value	Units
Storage Temperature Range	-65 to +175	$^\circ\text{C}$
Maximum Junction Operating Temperature	+175	$^\circ\text{C}$
Total Device Dissipation	1.0	Watt
Thermal Resistance Junction to Lead	53.5	$^\circ\text{C} / \text{W}$
Thermal Resistance Junction to Ambient	100	$^\circ\text{C} / \text{W}$

These ratings are limiting values above which the serviceability of the diode may be impaired.

DEVICE MARKING DIAGRAM

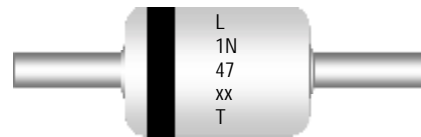

L : Logo
 Device Code : CM1N47xxT
 VZ Tolerance (T) : A = $\pm 5\%$
 C = $\pm 2\%$

Specification Features:

- § Zener Voltage Range 3.3 to 56 Volts
- § Through-Hole Device Type Mounting
- § Hermetically Sealed Glass
- § Compression Bonded Construction
- § All External Surfaces Are Corrosion Resistant And Leads Are Readily Solderable
- § RoHS Compliant
- § Solder Hot Dip Tin (Sn) Terminal Finish
- § Cathode Indicated By Polarity Band



ELECTRICAL SYMBOL

Electrical Characteristics $T_A = 25^\circ\text{C}$ unless otherwise noted

Device Type	$V_Z @ I_{ZT}$ (Volts) Nominal	I_{ZT} (mA)	$Z_{ZT} @ I_{ZT}$ (Ω) Max	I_{ZK} (mA)	$Z_{ZK} @ I_{ZK}$ (Ω) Max	$I_R @ V_R$ (μA) Max	V_R (Volts)
CM1N4728A	3.3	76	10	1	400	100	1
CM1N4729A	3.6	69	10	1	400	100	1
CM1N4730A	3.9	64	9	1	400	50	1
CM1N4731A	4.3	58	9	1	400	10	1
CM1N4732A	4.7	53	8	1	500	10	1
CM1N4733A	5.1	49	7	1	550	10	1
CM1N4734A	5.6	45	5	1	600	10	2
CM1N4735A	6.2	41	2	1	700	10	3
CM1N4736A	6.8	37	3.5	1	700	10	4
CM1N4737A	7.5	34	4	0.5	700	10	5
CM1N4738A	8.2	31	4.5	0.5	700	10	6
CM1N4739A	9.1	28	5	0.5	700	10	7
CM1N4740A	10	25	7	0.25	700	10	7.6
CM1N4741A	11	23	8	0.25	700	5	8.4
CM1N4742A	12	21	9	0.25	700	5	9.1
CM1N4743A	13	19	10	0.25	700	5	9.9
CM1N4744A	15	17	14	0.25	700	5	11.4

Electrical Characteristics $T_A = 25^\circ\text{C}$ unless otherwise noted

Device Type	$V_Z @ I_{ZT}$ (Volts) Nominal	I_{ZT} (mA)	$Z_{ZT} @ I_{ZT}$ (Ω) Max	I_{ZK} (mA)	$Z_{ZK} @ I_{ZK}$ (Ω) Max	$I_R @ V_R$ (μA) Max	V_R (Volts)
CM1N4745A	16	15.5	16	0.25	700	5	12.2
CM1N4746A	18	14	20	0.25	700	5	13.7
CM1N4747A	20	12.5	22	0.25	750	5	15.2
CM1N4748A	22	11.5	23	0.25	750	5	16.7
CM1N4749A	24	10.5	25	0.25	750	5	18.2
CM1N4750A	27	9.5	35	0.25	750	5	20.6
CM1N4751A	30	8.5	40	0.25	1000	5	22.8
CM1N4752A	33	7.5	45	0.25	1000	5	25.1
CM1N4753A	36	7	50	0.25	1000	5	27.4
CM1N4754A	39	6.5	60	0.25	1000	5	29.7
CM1N4755A	43	6	70	0.25	1500	5	32.7
CM1N4756A	47	5.5	80	0.25	1500	5	35.8
CM1N4757A	51	5	95	0.25	1500	5	38.8
CM1N4758A	56	4.5	110	0.25	2000	5	42.6
CM1N4759A	62	4.0	125	0.25	2000	5	47.1
CM1N4760A	68	3.7	150	0.25	2000	5	51.7
CM1N4761A	75	3.3	175	0.25	2000	5	56.0

V_F Forward Voltage = 1.2 V Maximum @ $I_F = 200$ mA for all types

Notes:

1. TOLERANCE AND TYPE NUMBER DESIGNATION (V_Z)

The type numbers listed have a standard tolerance on the nominal zener voltage of $\pm 5\%$. Device tolerance of $\pm 2\%$ is indicated by a "C" instead of an "A".

2. SPECIALS AVAILABLE INCLUDE

Nominal zener voltages between the voltages shown and tighter voltage, for detailed information on price, availability and delivery, contact you nearest Tak Cheong representative.

3. ZENER VOLTAGE (V_Z) MEASUREMENT

The zener voltage (V_Z) is tested under pulse condition.

4. ZENER IMPEDANCE (Z_Z) DERIVATION

The zener impedance is derived from the 60 cycle AC voltage, which results when an AC current having an RMS value equal to 10% of the DC zener current (I_{ZT} or I_{ZK}) is superimposed on I_{ZT} or I_{ZK} .

Typical Characteristics

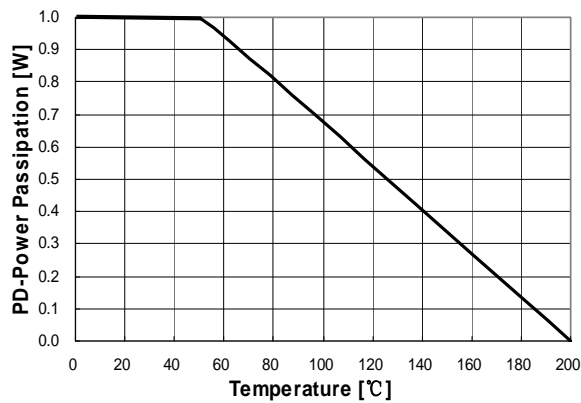

Figure 1. Power Dissipation vs Ambient Temperature
Valid provided leads at a distance of 0.8mm from case are kept at ambient temperature

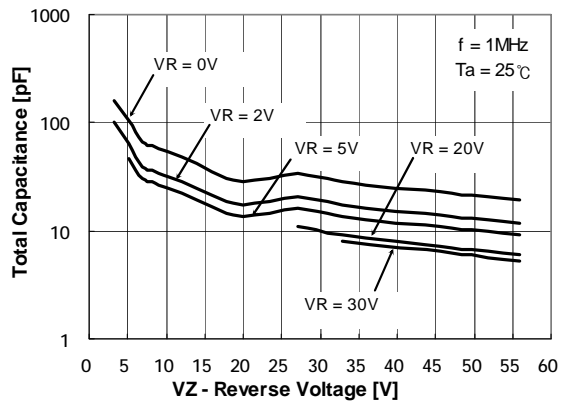

Figure 2. Total Capacitance

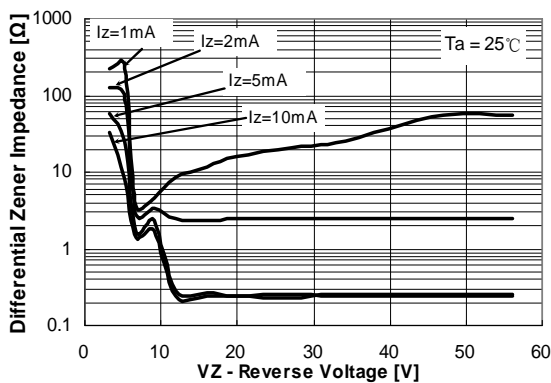

Figure 3. Differential Impedance vs. Zener Voltage

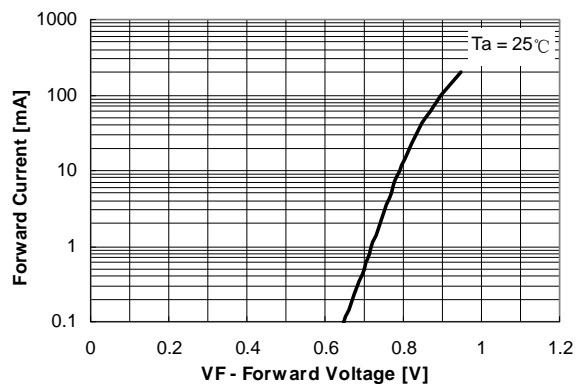

Figure 4. Forward Current vs. Forward Voltage

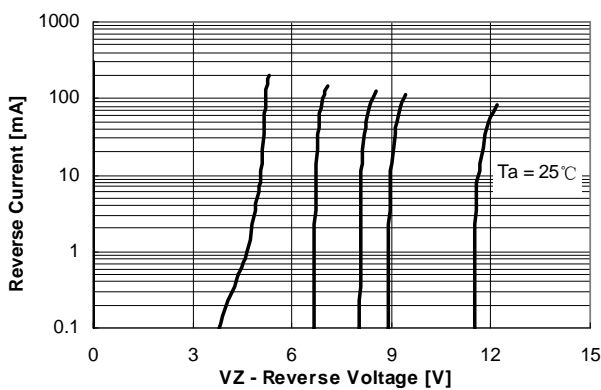

Figure 5. Reverse Current vs. Reverse Voltage

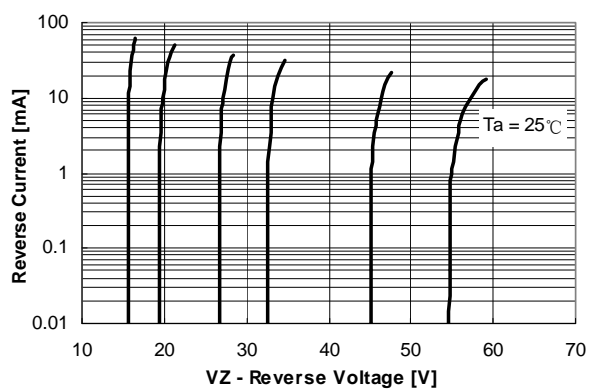
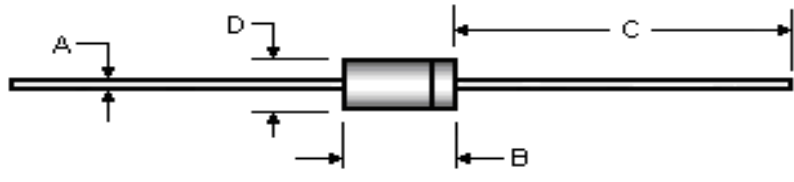

Figure 6. Reverse Current vs. Reverse Voltage

Package Outline

Package	Case Outline				
DO-41					
	DO-41				
	DIM	Millimeters		Inches	
		Min	Max	Min	Max
	A	0.68	0.81	0.027	0.032
	B	---	4.25	---	0.167
C	25.40	---	1.000	---	
D	2.10	2.60	0.083	0.102	

Notes: .

1. DO41 polarity denoted by cathode band.